

INDUSTRIAL DIESEL ENGINE

**KUBOTA 05-SERIES (3-cylinder)**

# D1005-E3B



## RATED POWER

**17.5 kW/3000 rpm**

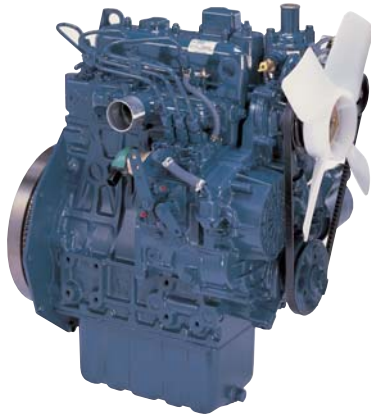

## PERFORMANCE CURVE

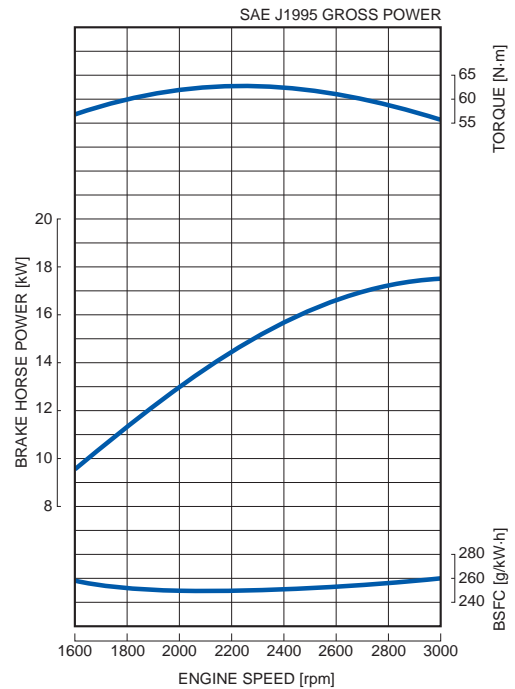

## FEATURES with BENEFITS

### Emissions

- The D1005 engine complies with EPA Tier 4 emissions regulations. These are the most stringent emissions regulations in the world in this class.

### Durable Power

- The Kubota 05-Series is an established leader in its horsepower range and has been the preferred power source of various industrial equipment manufacturers.
- The D1005 engine offers a seamless transition from Tier 2 to Tier 4 by maintaining the same footprint and hardware mounting points with only slight performance changes from the Tier 2 engine.

### Clean and Quiet Power

- Kubota's original E-TVCS (Three Vortex Combustion System) has been improved. The combustion chamber and piston recess were optimized to achieve a 50% lower particulate matter (PM) level.

## GENERAL SPECIFICATION

Model		<b>D1005-E3B</b>
Emission Regulation		Tier 4
Type		Vertical 3-cycle Liquid Cooled Diesel
Number of Cylinders		3
Bore	mm (in)	76 (2.99)
Stroke	mm (in)	73.6 (2.90)
Displacement	L (cu.in)	1.001 (61.08)
Combustion System		Indirect Injection
Intake System		Naturally Aspirated
Maximum Speed	rpm	3000
Output: SAE J1995 Gross Power	kW	17.5
	hp	23.5
	ps	23.8
Direction of Rotation		Counterclockwise Viewed on Flywheel
Oil Pan Capacity	L (gal)	5.1 (1.35)
Starter Capacity	V-kW	12-1.2 [US] / 12-1.4 [EU]
Alternator Capacity	V-A	12-40
Length	mm (in)	497.8 (19.60)
Width	mm (in)	396.0 (15.59)
Height (1)	mm (in)	602.0 (23.70)
Height (2)	mm (in)	227.6 (8.96)
Dry Weight	kg (lb)	93.0 (205.0)

\*Specification is subject to change without notice.

\*Dry weight is according to Kubota's standard specification.  
When specification varies, the weight will vary accordingly.

\*SAE J1995 Gross Power: 1-hour rating based on engine without cooling fan, air cleaner and muffler, with alternator.

## DIMENSIONS

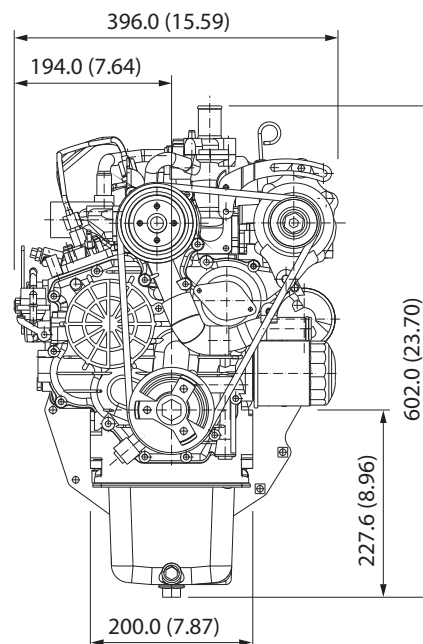
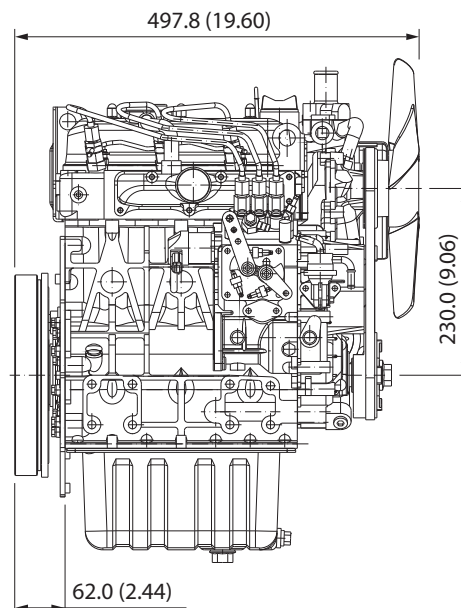

**Kubota Corporation**

2-47, Shikitsuhigashi 1-chome, Naniwa-ku, Osaka, 556-8601 Japan  
 Fax: +81 (0) 6 6648 /35 21  
<http://www.engine.kubota.ne.jp>

**Kubota (Deutschland) GmbH**

Senefelder Str. 3-5  
 63110 Rodgau

Phone: +49 (0) 6106 / 873 - 113

Fax: +49 (0) 6106 / 873 - 196

eMail: [motoren@kubota.de](mailto:motoren@kubota.de)

homepage: [www.kubota.de](http://www.kubota.de)